

SDD SERIES

Digital Doser



Technical Specifications

The SDD Series Digital Dosing System offers precise additive feeding for almost any plastics machine, whether your application is injection molding, blow molding, or extrusion. The SDD dosing unit uses a variable speed DC drive motor and dosing disc to precisely feed pellet or powder additives, at a set rate, into the throat of the processing machine. Precision design discs and closed loop control ensures high accuracy, dependability and repeatability.

Material changeover on the SDD dosing units is simple, release two quick disconnects and remove the additive station. An optional spare station can be used for an immediate changeover, which reduces downtime and reduces overall safety risk. The SDD dosing series is also available in the SDD2 configuration that offers the ability to use dual additives at different rates.

Features

Standard Features

- Disc style feeder module to dose pellets, micro pellets, granulate or powders
- Variable speed, closed loop drive
- A250 feeder control
- Extrusion or injection applications
- 110/1/60 operating voltage
- Choice of several styles and sizes of discs for precise additive feeding
- Clear plastic 4.4 liter additive hopper with fill cover
- Quick disconnect additive hopper for "off the machine" cleanout/material change
- 2" diameter material feed tube with 6" square mounting flanges (top and bottom)

Optional Features

- Spare station for immediate additive changes
- Optional motor speeds
- Optional hopper capacities
- Alarm – Audible, Alarm Light, Low Level Sensors
- Hopper loaders for automatic refill
- Special voltage
- Hoppers for main component
- Larger base piece for larger processing machines (3" or 4")

Product Diagrams

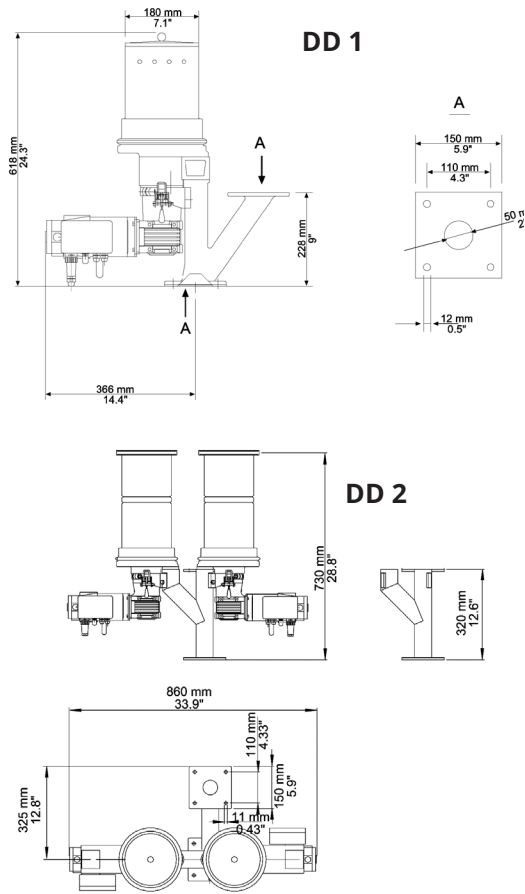

Advanced Controller

The microprocessor-based A250 controller can be set up for either Injection or Extrusion operation. In the extrusion mode, the controller can monitor extruder speeds and adjust the feeder motor to match. In injection mode, the controller has the ability to sense changes in screw recovery time and automatically adjust the feed time and motor speed to compensate. The A250 controller has a touch screen that is easy to operate and has storage of up to 50 recipes.

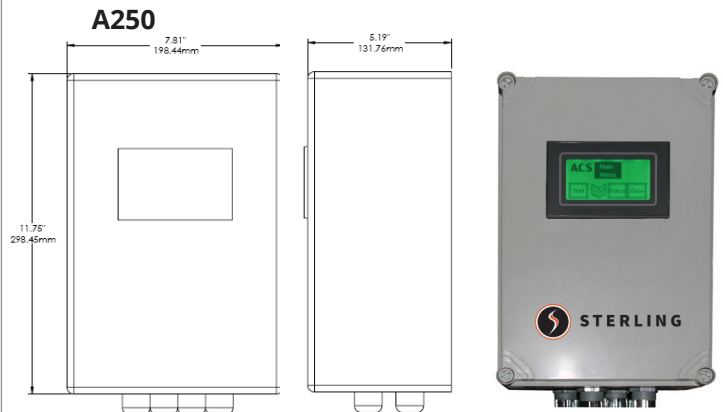

Specifications

Model	Description	Motor RPM	Additive Rate	
			Min., lbs./hr. (kgs./hr)	Max., lbs./hr. (kgs./hr)
SDD30-030672	72 pockets	3 or 11.5	0.12 (0.06)	9.6 (4.3)
SDD30-050660	60 pockets	3 or 11.5	0.18 (0.09)	8.5 (3.8)
SDD30-051040	40 pockets	3 or 11.5	0.45 (0.21)	27.0 (12.2)
SDD30-051725	25 pockets	11.5 or 38	0.72 (0.33)	47.1 (21.3)
SDD30-051818	18 pockets	11.5 or 38	1.32 (0.60)	85.9 (38.9)
SDT30-101820	20 holes	11.5 or 38	3.00 (1.29)	179.0 (81.2)
SDT30-102520	20 holes (oval)	11.5 or 38	2.77 (1.26)	211.1 (95.7)
SDT30-203012	12 holes	11.5 or 38	9.39 (4.26)	596.8 (270.7)
SDT30-204010F	10 pockets	11.5 or 38	12.00 (5.40)	948.3 (430.1)
SDP30-250940 (powder only)	40 pockets	3 or 11.5	Consult Factory	Consult Factory
DP30-050940 (powder only)	40 pockets	11.5	Consult Factory	Consult Factory

*Additive rate based on continuous feeding and 44 lbs./cu.ft. (0.7 g./cc.)
Minimum and maximum additive rate may vary based on specific motor and disc combinations selected.