

MDT SERIES

Take-Off Compartments

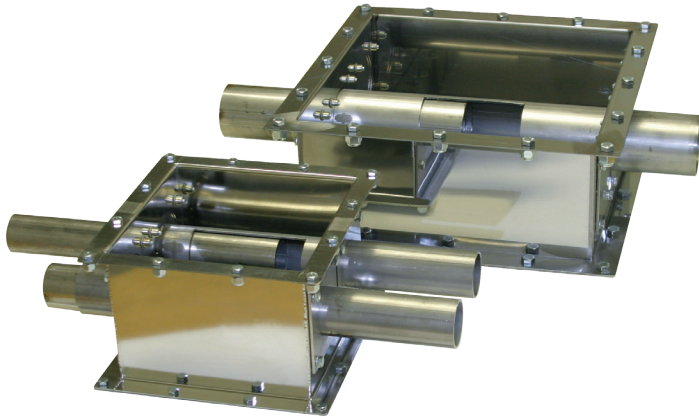

Technical Specifications

MDT Modular Take-Off Boxes are designed to introduce virtually any material into your vacuum conveying system. While these boxes are highly efficient for use with plastic pellets and long distances, they are excellent for use with regrind and hard-to-flow materials and provide durable construction in a simple modular design. The MDT Series take-off boxes feature stainless steel construction with stainless steel tube-in-tube assemblies for maximum flexibility in balancing the material flow into your conveying system. The versatile modular design is compatible with a wide range of applications and allows for easy assembly and cleanout.

Features

Standard Features

- Stainless steel box and tubes
- Dual tube (Tube-in-tube) take off assemblies
- Up to three take off assemblies per box
- Sight glasses on unused positions
- Ideal for conveying hard-to-flow material over long distances
- Available box sizes:
 - 16" (406mm) square flange – maximum three take off assemblies
 - 10" (254mm) square flange – maximum two take off assemblies

Optional Features

- Material clean-out gate
- Blank plate on bottom
- Adapter plate to mate to 7" x 7" or 9" x 9" square flange drying hoppers
- Take-off tube sizes:
 - 1.5" OD
 - 2.0" OD
 - 2.5" OD
 - 3.0" OD
 - 3.5" OD
 - 4.0" OD
 - 5.0" OD

Application Notes

- Check available clearance below bin mounting flange
- Pick correct box type to match your application
- Do not mix tube sizes without consulting the factory
- Use MDT dual tube modular take-off boxes if you are conveying hard-to-flow materials, such as flakes or powders
- Use MDT dual tube take-off boxes if you are conveying any material over 200 equivalent feet
- Consult factory for dry-air conveying applications or powder conveying applications
- Maximum three (3) box stack-up allowed

Product Diagrams

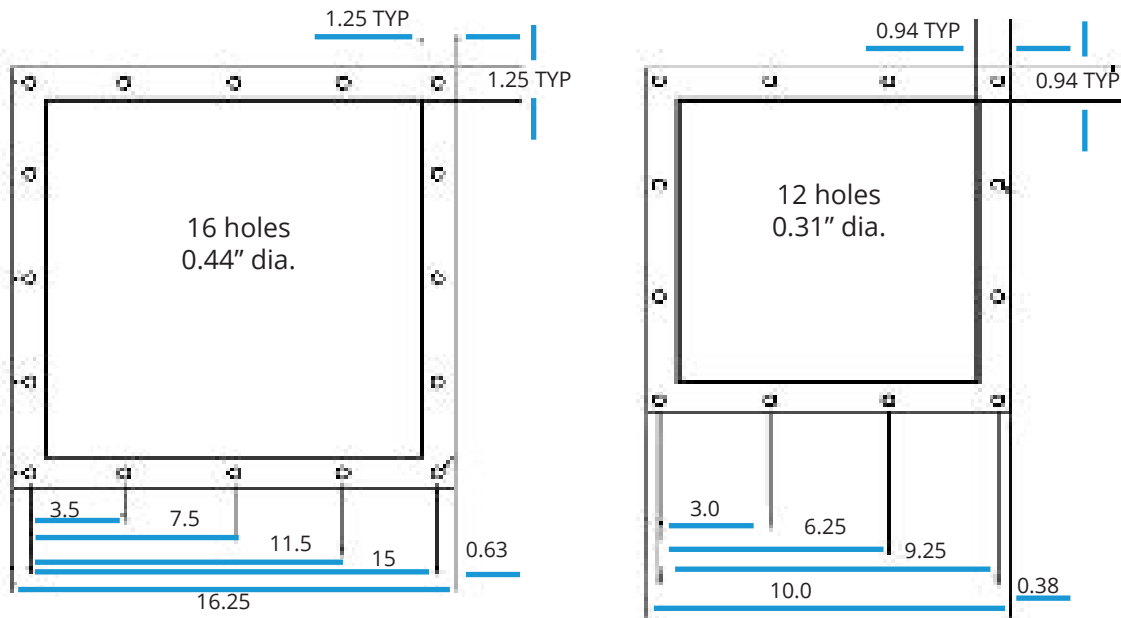

Style	Square Flange Size in (mm)	Height in. (mm)	Bolt Pattern		Number of tubes per MTO box					
			Top	Bottom	1.5"	2.0"	2.5"	3.0"	3.5"	4.0"
A	16 (406)	6 (152)	16 holes	16 holes	3			2		
B	10 (254)		12 holes	12 holes	2			1		

Clean-out Gates

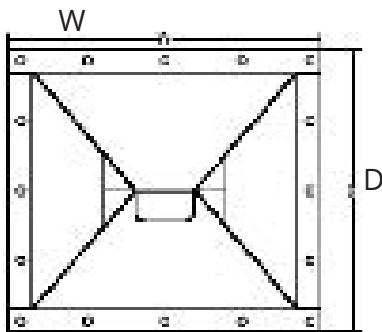

Style	H in. (cm)	W in. (cm)	D in. (cm)
A	6.94 (17.6)	16.25 (41.3)	16.25 (41.3)
B	4.31 (10.9)	10 (25.4)	10 (25.4)

