

BOX DUMPERS SERIES

Removal Materials



Technical Specifications

Box Dumpers remove material from containers and place it into your material handling system quickly and affordably. The line includes vertical lift and dump equipment, totally enclosed dust containment units, floor level, and elevated dumpers. All equipment comes in various capacities and your choice of carbon steel, stainless steel, or aluminum construction.

Features

Standard Features

- Lift and Rotation Capacity – 2500 lbs.
- Contained Power Units: Electric/Hydraulic or Air/Hydraulic
- 135° Dump Rotation
- Adjustable Box Retainer Bar
- Bronze Bushing at Pivot Point
- Pinch Point Safety Guards
- 5 volt Control Panel – NEMA 12 Enclosures
- 2" or 3" Hydraulic Cylinder
- Safety Flow Control Valve
- Dump Heights – 4' to 20'
- Heavy Duty Frame and Bucket Construction

Optional Features

- Available in Various Materials of Construction
- Large Lift Capacities
- Explosion Proof and Wash Down Electrics
- Adaption to Larger Containers
- Custom Enclosed Units for Dust Control

Product Diagrams

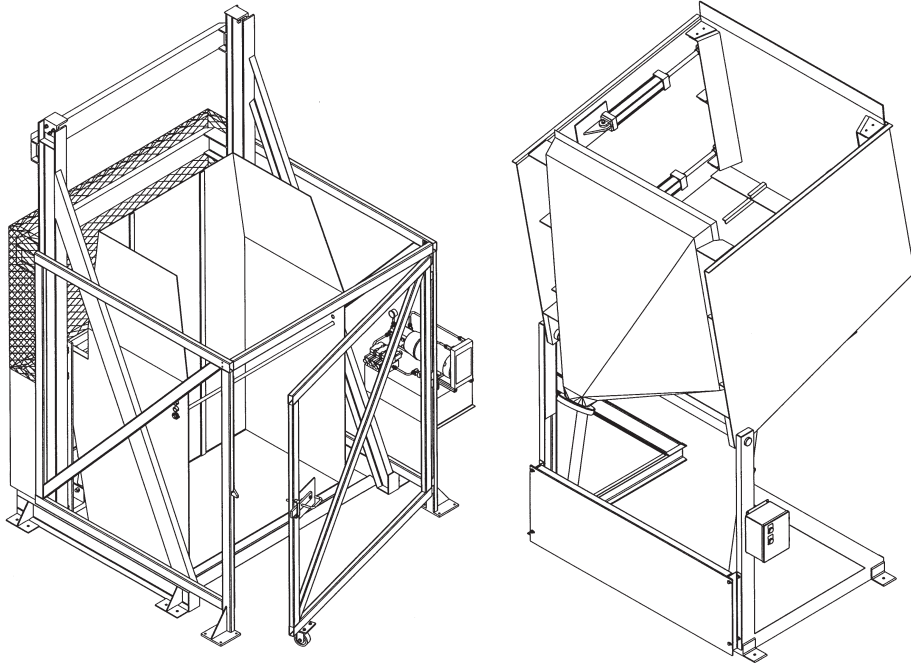

Specifications

Type	Motor	Width, in.	Dump Height, in.
Rear load	120/1/60	50	48
	460/3/60		60
Side load, left	120/1/60	50	36
	460/3/60		36
Side load, right	120/1/60	50	36
	460/3/60		36
Lift & Seal	460/3/60	50	60
High lift	460/3/60	50	96-120
			120-168
			168-192
			192-216
			216-240
			240-264
High lift & Seal	460/3/60	50	96-120
			120-168
			168-192
			192-216
			216-240
			240-264

Support Stands

Type	Width, in.	Height, in.
Rear	48	12-48
		49-60
Rear	52	12-48
		49-60
Side	55	12-24
		25-36
	50	37-48
		49-60

Safety Enclosure

Type
Use with box dumper
Use with lift and dump